



SEPTEMBER  
2009

## Activities•At•A•Glance

### September

- |    |                            |
|----|----------------------------|
| 3  | Check-In Day               |
| 9  | WEB – Grade 6 only         |
| 10 | All Students Report        |
| 21 | School Pictures            |
| 23 | Site Council Meeting 3:40p |
| 24 | Open House; 6:30p          |

### October Preview

- |    |                                      |
|----|--------------------------------------|
| 2  | River Walk                           |
| 5  | Kelly Co-Pilots Meeting; 7p          |
| 9  | NO SCHOOL: Statewide In Service      |
| 14 | Site Council Meeting; 3:30p          |
| 15 | River Walk Party; 6:30-8:30p         |
| 16 | NO SCHOOL: Grading/Staff Development |
| 30 | Fall Fest                            |

# School News

INFORMATION AND NEWS FOR PARENTS

## *Welcome to New Principal*

José da Silva will be taking the helm at Kelly this year. He comes highly recommended and is thrilled to have the opportunity to work with our students, families and community members. Mr. da Silva came to the Eugene 4J district three years ago when he assumed the responsibility of Assistant Principal at Monroe Middle School. Prior to his tenure in 4J Mr. da Silva spent 11 years at Marist High School where he served as a teacher, counselor, and dean of students. José brings with him a broad scope of experience and enthusiasm that will serve him well as principal of Kelly Middle School. Please watch our website to find out more about how he will be working in partnership with the entire Kelly community to move our school forward.

## *WEB*

### **Where Everyone Belongs**

WEB is a middle school transition program that welcomes 6<sup>th</sup> graders and makes them feel comfortable through the first year of their middle school experience. The WEB middle school transition program trains members of the 8<sup>th</sup> grade class to be WEB Leaders and it is built on the belief that students want to and can help other students succeed. Our 8<sup>th</sup> graders act as positive role models, motivators, and teachers who guide 6<sup>th</sup> graders to discover what it takes to be successful in middle school.

WEB's goal is to provide a structure in which students make real connections with each other. Through this program students learn that people at school care about them and their success. WEB begins with a fun and energetic orientation day that gets the 6<sup>th</sup> graders excited and proud to be attending their new middle school. It also allows them to begin developing relationships with other students as well as learn strategies that will contribute to their middle school success. After orientation WEB continues, providing a variety of both academic and social follow up activities throughout the year.

## *Leader in Learning*

### **Kelly Makes AYP**

We are happy to announce that Kelly MS met our Annual Yearly Progress (AYP) Goals. AYP is a measure that The No Child Left Behind Act requires to determine whether schools are moving toward the goal of having all students meet rigorous state academic standards. Kelly teachers and staff members work incredibly hard to make sure your student is receiving a top-notch education, and it is phenomenal for our work to be validated and recognized with this designation. You can go online to the Oregon Department of Education web site to view all schools results, <http://www.ode.state.or.us/data/reportcard/reports.aspx>



## Kelly Co-Pilots

The Kelly Co-Pilots is the name of our parent organization. We meet on the second Monday of each month with the exception of December when we will have a book fair which will take the place of the meeting. This book fair is a result of parents wanting to do some fundraising, while adding to our school library at the same time.

The topics covered in our meetings are generated by the parents. On the first meeting, October 5, we will elect our representatives to the Kelly Site Council, meet new staff members, hear the results of the River Walk fundraiser and fill out surveys to set up topics for future Co-Pilot meetings. Watch the newsletter each month for the meeting reminder.

## Vision Statement

Kelly Middle School is a student-centered community recognized for academic excellence, social responsibility, and cultural awareness.

## Mission Statement

The mission of Kelly Middle School is to create an inclusive learning environment that challenges, prepares, and empowers students to be contributing and compassionate citizens of the world.

## Technology Mission Statement

In order to prepare students for a technology-rich society, we will weave instructional technology, critical thinking, and global communication into everyday teaching and learning.

## Student Check-In Day

### Pay fees and pick up schedule's

ALL students need to come to the school cafeteria on Thursday, September 3, during the following times:

- 3-4 p.m. Last name beginning with A -J
- 4-5 p.m. Last name beginning with K-S
- 5-6 p.m. Last name beginning with T-Z

After paying school fees, students may pick up their class schedule. If you can volunteer to help with schedule pick up, please call the school office at 790-4740.

## About School Fees

Fees:

**Program Fee:** *Yujin Gakuen includes stipends for interns or payments to homestay families.*

**General Fee:** *Technology supplies, miscellaneous supplies, fitness center and rock climbing.*

**Planner Fee:** *Spiral bound student-planner with room for homework and deadline reminders for the entire year. Teachers help students in the use of their planners.*

	Colin Kelly	Yujin Gakuen
General Fee	23.00	23.00
Program Fee		60.00
<b>Planner</b>	<b>7.00</b>	<b>7.00</b>
Total	30.00	90.00

Optional Fees:

**Student Body Card. . . \$10**

The purchase of an activity card supports student body activities such as assemblies, fests, speakers and other incentives. An activity card provides current identification as well as reduced fees to local merchants and some high school games and free fare on any LTD bus for the current school year.

**Yearbook . . . . . \$23**

For an additional \$5, you may have your yearbook personalized with your name on the front. Also, for track and field fanatics there will be an 8- page color track insert! This insert costs \$8, and will follow the track team from preseason all the way to districts!

Cafeteria:

Breakfast . . . \$1.35      Lunch . . . \$2.50

Breakfast and lunch service begins on Thursday, September 10; breakfast service starts at 8:30 a.m. You can pay on your student's account directly to the cafeteria staff or online. Please make out a separate check from the other school fees to purchase lunches for your student. The school also has a-la-carte menu items.

## First Day of School

**Incoming 6<sup>th</sup> graders...mark your calendars for our first WEB event! 6<sup>th</sup> graders should plan on reporting to school at 9:00 a.m. on September 9 to participate in a variety of WEB activities.** Students will stay through lunch and then meet with their homeroom teachers in the afternoon. Afternoon activities will include meeting staff, getting lockers, and becoming acquainted with the school planner. This first day of school will end at 2:30!

Buses will operate on a special schedule to accommodate this abbreviated day. (Regular bus schedules are enclosed). All grades will attend school on Thursday, September 10.

## 7th and 8th Graders

Students entering 7th and 8th grades should report to their first period class on Thursday, September 10, at 9:00 a.m. They should bring their school supplies. If your student missed Student Check-In Day, they need to arrive by 8:30 a.m. and report to the school office to pick up their schedule and pay their fees. Students new to Kelly are invited to a new student orientation on Wednesday, September 9, from 2-3 p.m. in the library.

## First Site Council Meeting

The purpose of Site Council is to share information, make decisions that affect the entire school, and to provide a support base for Kelly Middle School. Site Council makes major decisions, including the development and implementation of the school improvement plan, as well as other school policies and programs. Site Council is comprised of staff, students, and parents representing Kelly and Yujin Gauken.

We are in need of parent representatives for the upcoming school year. Site Council parents attend meetings on the second Wednesday of every month from 3:40 – 5:00 p.m. and Co-Pilots meetings throughout the school year. The first site council meeting will be September 23 and is held in our library. If you are interested in applying for a parent position please contact the front office, at 790-4740, for an application. The application deadline is Monday, September 28.

## 6<sup>th</sup> Grade Parent Coffee Meetings

This fall Mr. da Silva will be hosting small, informal coffee meetings for 6th grade parents in the library. We will discuss being a 6th grade parent, cover general school information and answer any questions you may have. Shelley Hoffman, our Volunteer Coordinator will be available to answer questions also.

**Coffee meetings will be 10-10:45 a.m. on the following dates:**

September 22, last names beginning with A-M are invited

September 29, last names beginning with N-Z are invited

October 6, meeting will be in Spanish

6<sup>th</sup> grade parents will receive a postcard invitation to join one of these meetings.

## Open House

Mark your calendar for September 24 at 6:30 p.m. Open House is a great opportunity to meet your child's teachers, familiarize yourself with the curriculum, learn about classroom expectations, and explore the school.

Parents will follow a mini-schedule, similar to the one their student follows every day. You will spend time in each classroom, where teachers will discuss curriculum, goals for the year, and classroom expectations. You will also have an opportunity to meet our administrators and Related Arts/Flex teachers.

Because time is limited, this is not a time for discussing individual student issues. Should there be a need to meet with teachers, you are invited to contact the teacher (via email or by calling the school office) and schedule an appointment. In addition, parent-teacher conferences will be held in November, after teachers have become more familiar with students.

## BEST for Kids and Families 2

The after school program is in its second year of the 21st Century Community Learning Center Grant. The partnerships with the City of Eugene and River Road Parks and Recreation will continue their awesome support of our after school program. The program will have four main components, which are Homework Club, Snack, Enrichment Classes and Transportation. The program runs Monday-Thursday from 3:30-5:30 p.m. Flyers will be sent home with students the third week of school. If you have any questions please contact Tammi Brown at 790-4740.

## Kidsport Vouchers

Thanks to a generous donation from Zip-O-Logs, our school has been 'adopted'! Through the KIDSPORTS 'Adopt-A-School' program, 15 kids (@ a value of \$100 each) at Kelly Middle School will have an opportunity to participate in one fall sports for free. The sports programs include Tackle Football, Fall Soccer, Volleyball, and Basketball. See the Kidsport web page for registration deadline information: [www.kidsports.org](http://www.kidsports.org). Check with the Kelly office for the vouchers.

## School Supplies

### All Grades

- Scientific calculator
- College-ruled notebook paper
- 2 - 1 1/2" 3-ring notebook binders
- 2 - sets of notebook dividers
- 2 - zipper pouches for notebooks
- 1 - ruler with metric measure
- 1 - set colored pencils
- 1 - pair of scissors
- 1 - portable pencil sharpener
- 1 - large eraser
- 6 - 70-page spiral notebooks
- 1 - box tissues (turn into teacher)
- 1 - set washable marking pens
- 10 - #2 pencils\*
- 2 - pens\*
- 1 - large glue stick\*

### 7th & 8th Grade Math

- Compass
- Protractor

### Optional for Computer Use

- Headphones for use w/ laptop
- Thumb drive

*\*Check your students supplies every 9 weeks and replace as needed.*

### P.E. Supplies

- Padlock for P.E. basket
- Shorts
- White T-shirt
- Socks
- Tennis Shoes

*P.E. Lockers:* All students will be assigned a gym basket. Students must supply their own padlock and keep baskets locked at all times. If there is an emergency and a student cannot be located, the lock may have to be cut.

*P.E. Dress Requirements:* Dressing down for P.E. is mandatory. Students are expected to wear shorts or sweats, a T-shirt, socks, and tennis shoes. Showers and towels are available. If students forget P.E. clothes, there will be laundered uniforms available, which students will be expected to wear.

## Student Arrival

Students will be permitted in the building at 8:15 a.m., at which time they can gather in the Flight Deck where they can mingle with their peers. Students, who have pre-arranged appointments with staff members, prior to 8:15 a.m., may enter the building, check-in at the office to get a pass to proceed to their appointment.

Please be aware that students being dropped off prior to 8:15 a.m. are NOT under the supervision of Kelly personnel. As such, the activities and whereabouts of these students are not closely monitored. While we realize busy schedules can present transportation challenges, we are asking for your support as we strongly encourage families to please avoid dropping students off prior to 8:15 a.m.

Thank you, in advance, as we work together to ensure the safety and well-being of our students.



## Laptops

### Student Responsibility

Kelly Middle School in "in front of the pack" when it comes to technology hardware and its use in everyday teaching and learning. As such, each student is assigned a laptop for use during the school day. To increase longevity, we expect students to treat equipment with respect, and within the parameters we have established for proper usage. Please understand that mistreatment, careless handling, and/or improper use of laptops/desktops may result in loss of privileges. In addition, students will be expected to make restitution should repairs/replacement of equipment be necessary.

## Absences & Homework

If your student is going to be absent, a call must be made to the school office (790-4740), preferably no later than 9:30 am. If you are unable to phone the school, please send a note (explaining your child's absence) when your student returns to school. As a friendly reminder, according to Oregon Truancy Regulations, if your student has eight half-day absences in any four-week period, you will receive a letter from the school notifying you of our attendance concerns. Please understand that if irregular attendance continues, we will be obligated to make a referral to a truancy officer for further investigation.



If you are planning to take your student out of school for family business or vacations, please let the school office know in advance. Also, be sure that you have made advance plans with each of your child's teachers. Your student is responsible to complete any work that will be missed.

## Messages for Students

To avoid classroom disruptions, we ask that you please communicate "after school plans" with your students before they leave for school in the morning. Should you need to get a message to your child during the school day, we will place their name on a *Message Board* located just outside the front office. Students pass by this board on a regular basis and know that if their name is on the board they have a message waiting in the office.

On a related note, if your student will be leaving before school is excused for the day, s/he must have a signed note from you. This note becomes their pass from class at the appointed time. Your student must also check-out at the office before leaving campus. For safety reasons, at no time may students leave campus without checking out in the office—NO EXCEPTIONS.

## Lockers

Lockers are school property and provided as a convenience for students. The school reserves the right to inspect lockers at any time. Students agree to the following conditions:



1. Keep your combination private.
2. Never get into another person's locker, and do not be in possession of the combination(s) of other locker(s).
3. The security of this locker is your responsibility. The school is **NOT** liable for any items taken from lockers.
4. Personal locks are not allowed on hall lockers.

## Personal Property

Personal property can be vulnerable to theft and may be disruptive to the learning environment. To reduce the risk of personal loss and to minimize disruptions, we ask that students adhere to the following guidelines regarding personal property:

**Items that are brought to school at the student's own risk** ~ all electronic devices such as ipods, cell phones, digital cameras, Gameboys, etc. All electronic devices should be turned off, and not in use, during the school day (except for lunch, with the exception of cell phones, which are not permitted during school hours). Electronics may be confiscated if they are in use at inappropriate times.

**Items that are not allowed at school** ~ matches, lighters, laser pointers, squirt guns, or any other item that may disrupt learning. **NEW THIS YEAR** ~ personal laptops are not allowed at school, except under special, pre-arranged, circumstances. With wireless systems in place, we are unable to monitor Internet usage on laptops not owned by Kelly Middle School and the 4j school district.

Please understand that the school is not responsible for lost, damaged, or stolen personal property.

# Cell Phone Usage

## Check It Out!

With increased ownership and usage of cell phones, schools have been faced with the challenge of managing not only talking on cell phones, but also texting, video-recording, and photo options that are now available on most cell phones. As such, these electronic devices have become a distraction not only to the learning environment, but have been a source for increased student discipline. In response, we will be implementing a new policy for cell phone use this year. Students will be allowed to use their cell phones before/after school, only. Cell phones should be turned off and stored in lockers during the school day. Students needing access to a phone during lunch can use the office phone to contact parents/guardians. Should you need to get a message to your child during the school day, feel free to contact the school office. We are asking for your support as we implement the following consequences for cell phone use during the school day:

**1<sup>st</sup> Offense:** Student must pick the phone up from an administrator, at the administrator's convenience.

**2<sup>nd</sup> Offense:** Parent must pick up the phone from the front office

**3<sup>rd</sup> Offense:** Student loses cell phone privileges for the remainder of the year.



## Student Drop Off/Pick Up

### Important Safety Procedures

To promote safety for all, the following is our student drop off/pick up procedures.

1. The North parking lot (the lot facing Howard Ave.) will be staff parking ONLY.
2. The North parking lot (the lot facing Howard Ave.) will be dedicated to BUSES ONLY. Students should NOT be dropped off using this lot.
3. The West parking lot (the lot facing N. Park) will be dedicated to visitor parking and student drop off/pick up.
4. When using the West lot, adhere to the "enter" and "exit" signs.
5. When dropping off/picking up your student, use the "pause parking" lane, leaving the open lane free for through traffic.

## New Skateboarding Rules

Skateboarding on Kelly campus is no longer permitted. For the last few years Kelly has allowed skateboarding on campus in certain places and during certain hours. However, due to safety and liability issues this practice will no longer be allowed.

Students who use skateboards as their transportation to and from school may continue to do so. As soon as you come to the edge of campus, please pick your board up and carry it to the building and make sure it is secured in your locker during the school day.

## Painless Ways to Fundraise

Kelly Families this year our school will be participating in several new fundraising opportunities. Families may be familiar with them from your students grade school days. Kelly is now doing Box Tops 4 Education, Campbell's Labels for Education, ESCRIP, Target Red Card, and EcoPhones (recycling cell phones, ink jet cartridges, iPods, laptops, etc.). Take a few minutes to check out the links on the Kelly Website. Click Contact Us, then click Parent Groups for information. Information will be sent home with students when school begins. We will have collection jars for Box Tops and Campbell's in each classroom and the office. There will be a container for your cell phones, ink, etc in the office. So start collecting now. Questions contact Shelley Hoffman [hoffman\\_sh@4j.lane.edu](mailto:hoffman_sh@4j.lane.edu) or 914-8202.

## River Walk

Each year the entire student body participates in the River Walk. This event raises funds for the student-body activities, equipment and field trips. Last year students raised over \$18,000. Students start collecting pledges on Friday September 18. The River Walk is held during school hours on Friday October 2. Students, staff and parent volunteers walk a 7 mile loop course from school, along the river and back again. We all stop at Maurie Jacobs Park for a barbeque and fun activities. There are a variety of volunteer positions available – making phone calls, serving lunch, coordinating collected funds and, of course, walking! This is a great way to get to know other students, parents and staff. Call Terri Hunt at 790-4740 if you are interested.

## Important Info

The first week of school your student will bring home a packet with important information. Several of the forms need to be filled out and returned to school.

- **Universal Permission Slip - 6<sup>th</sup> Grade Only**

The Universal Permission Slip will provide the school with permission (or not) for your student to participate/experience a variety of activities once granted on individual forms.

- **Newsletter On Line**

In the spirit of conservation and convenience, we will be emailing our newsletter to parents. Starting in October, we will no longer be sending newsletters through the mail. Rather we will email the newsletter and also post it on our web site. Please complete the form with the email address you would like the newsletter sent to.

- **LTD Sticker**

Students in grades 6-12 can ride LTD free beginning September 1, 2009 through June 30, 2010. To obtain the free LTD pass, fill out the form students will bring home the first week and return to school. Students must obtain an Student Body card to utilize their pass.

- **Student Insurance**

Student accident and health insurance at affordable rates, offered through a private company.

- **School Picture Flyer**

The flyer has all the information on school picture packets. The picture packet flyer, with the money collection envelope, will be sent home the Friday before picture day.

# Principally Speaking

By José da Silva, Kelly Middle School Principal

Welcome back for the 2009-2010 school year! I am excited to be the new principal at Kelly Middle School and am eager for the opportunity to get to know you. At Kelly, we believe it is important for families and schools to work together to ensure student success. We know that



*Principal, José da Silva*

no one is more aware of your child's potential than you are, and we would like to draw on that knowledge and learn from you. We are aware of the enormous benefits to our students when the school and families work together to support learning. Therefore, over the next few weeks and throughout the year, we will be sharing our expectations for our students' academic performance and conduct. Together we can watch our students grow and flourish at Kelly Middle School.

We would like to welcome the following new staff members:

- **Jan Christensen** comes to Kelly from the Ashland School District, where she has taught many different music and band classes to elementary, middle and high school age children. She has a particular passion for working with middle school age children and is excited to bring her experiences as a world traveler and musician to Eugene. She is a particular fan of the marimba and has spent substantial time in Zimbabwe studying this instrument.
- **Janice Hornsby** has worked in the district for the last 4 years as a counselor. She comes to us with strong skills in working with children and families and is excited to get to know the Kelly community. Most recently she was at the elementary level working with children at Harris and Adams schools, and before that she worked at Jefferson Middle School.
- **Joyce Johnson** has taken a new position in our building as Intervention Specialist. We are sorry to see her leave her current position as one of our Special Education Educators; however, we are excited that she will be focusing her efforts on helping all our students achieve high levels of learning.

## Nuts & Bolts

---

### Medications

School personnel may assist a student with prescription medication only if it is in its original container, properly labeled by the pharmacist. It will be stored in a locked cupboard in the school office. Contact the school office for medication consent forms and details.

A one-day's supply of nonprescription medication may be carried by a student only if they also carry a note from a parent specifying the name of the medication and dose to be taken. The same guidelines apply to emergency medication inhalers.

### Student Health

If you missed 10 days of work for illness would you keep your job? What about 15 or 20 days? If your students misses 15 days each year will they graduate from High School? The answer: probably not.

Your child begins to learn the importance of school in kindergarten and attendance is one of the critical factors in determining their academic success. Children get sick, and when they are sick they aren't learning much. When your student is running a fever, can't keep their mucous contained or vomiting we don't want them in school exposing the rest of us. However a few sniffles, occasional cough, or other minor ailment is not a good excuse to miss school. If your child isn't feeling well in the morning and suddenly is feeling better, bring them to school.

School district recommendations are **fever free for 24 hours prior to returning** to school. That means that if they had a temperature over 100 degrees in the afternoon they should not attend school the next day. The same applies to vomiting, if your child vomited in the afternoon we don't want them at school the next day.

When a child is home sick they need rest: that means no TV or video games. Books and quiet activities done in bed or on the couch are good for children. If a student stays home sick, they shouldn't attend sports practice or play with friends after school even if they are feeling better. If you have questions or would like to talk about your child's health, please feel free to call me, Robin Wellwood, RN 710-0345.

### Non-Custodial Parents

The 4J School District is able to provide co-custodial or non-custodial parents a duplicate copy of all district-labeled mailings. Please let us know if you would like a name added to your student's enrollment information.

# Kelly Bus Runs

If you have questions about bus routes please call Transportation at 790-7474.

Updated 8/10/09

Route ID: NE12  
TO KELLY MS

8:02 AM ----- ON W 8TH @ POLK  
8:03 AM ----- ON W 8TH @ VAN BUREN  
8:04 AM ----- ON W 8TH @ 767 W 8TH  
8:06 AM ----- ON W BROADWAY @ WASHINGTON  
8:09 AM ----- ON W 8TH @ 265 W 8TH  
8:10 AM ----- ON W 8TH @ 555 W 8TH  
8:13 AM ----- ON N LAWRENCE @ 65 LAWRENCE  
8:16 AM ----- ON WASHINGTON @ 67 WASHINGTON  
8:18 AM ----- ON JEFFERSON @ 142 JEFFERSON  
8:20 AM ----- ON W 4TH @ MADISON  
8:21 AM ----- ON W 4TH 939 W 4TH  
8:22 AM ----- ON POLK @ W 5TH  
8:26 AM ----- ON W 5TH @ BLAIR  
8:29 AM ----- ON CLARK @ 925 CLARK  
8:30 AM ----- ON GRAND @ CLARK  
8:32 AM ----- ON CROSS @ CROSS PL  
8:40 AM ----- KELLY MIDDLE SCHOOL

Route ID: NE41  
TO KELLY MS

8:16 AM ----- ON N PARK @ ELKAY  
8:18 AM ----- ON PARK @ WILLOW  
8:19 AM ----- ON PARK @ CHERRY  
8:20 AM ----- ON PARK @ 723 PARK  
8:21 AM ----- ON PARK @ DORRIS  
8:22 AM ----- ON KNOOP @ 25 KNOOP  
8:23 AM ----- ON MAYFAIR @ MERRILL CT  
8:24 AM ----- ON MAYFAIR @ STEVENS  
8:24 AM ----- ON HANSEN @ 152 HANSEN  
8:25 AM ----- ON HANSEN LN @ 136 HANSEN LN  
8:26 AM ----- ON ALBERTA @ 128 ALBERTA  
8:28 AM ----- ON RIVER RD @ CROCKER LTD  
8:29 AM ----- ON RIVER RD @ LTD STOP S - BRIARCLIFF  
8:40 AM ----- KELLY MIDDLE SCHOOL

Route ID: NE45  
TO KELLY MS

8:27 AM ----- ON ELKAY @ 119 ELKAY  
8:28 AM ----- ON ELKAY @ HOOVER LANE  
8:29 AM ----- ON ELKAY @ FAIRWAY  
8:30 AM ----- ON HORN @ MELVINA  
8:31 AM ----- ON HORN @ HODSON LANE  
8:32 AM ----- ON HORN @ ANDERSEN  
8:33 AM ----- ON HORN @ GOLDEN  
8:37 AM ----- ON HORN @ DALTON  
8:40 AM ----- KELLY MIDDLE SCHOOL

Route ID: NE12  
FROM KELLY MS

3:20 PM ----- KELLY MIDDLE SCHOOL  
3:37 PM ----- ON CROSS @ CROSS PL  
3:39 PM ----- ON GRAND @ CLARK  
3:40 PM ----- ON CLARK @ 925 CLARK  
3:42 PM ----- ON N LAWRENCE @ 65 LAWRENCE  
3:43 PM ----- ON WASHINGTON @ 67 WASHINGTON  
3:44 PM ----- ON JEFFERSON @ 142 JEFFERSON  
3:45 PM ----- ON W 4TH @ MADISON  
3:46 PM ----- ON W 4TH 939 W 4TH  
3:47 PM ----- ON POLK @ W 5TH  
3:49 PM ----- ON W 5TH @ BLAIR  
3:52 PM ----- ON W 8TH @ 265 W 8TH  
3:52 PM ----- ON W 8TH @ 555 W 8TH  
3:54 PM ----- ON W BROADWAY @ WASHINGTON  
3:56 PM ----- ON W 8TH @ 767 W 8TH  
3:57 PM ----- ON W 8TH @ VAN BUREN  
3:58 PM ----- ON W 8TH @ 1424 W 8TH

Route ID: NE41  
FROM KELLY MS

3:20 PM ----- KELLY MIDDLE SCHOOL  
3:32 PM ----- ON N PARK @ ELKAY  
3:34 PM ----- ON PARK @ WILLOW  
3:35 PM ----- ON PARK @ CHERRY  
3:36 PM ----- ON PARK @ WALNUT  
3:37 PM ----- ON PARK @ 723 PARK  
3:39 PM ----- ON PARK @ DORRIS  
3:40 PM ----- ON KNOOP @ 25 KNOOP  
3:41 PM ----- ON MAYFAIR @ MERRILL CT  
3:41 PM ----- ON MAYFAIR @ STEVENS  
3:42 PM ----- ON HANSEN @ 152 HANSEN  
3:43 PM ----- ON HANSEN LN @ 136 HANSEN LN  
3:44 PM ----- ON ALBERTA @ 128 ALBERTA  
3:45 PM ----- ON RIVER RD @ CROCKER LTD  
3:45 PM ----- ON RIVER RD @ LTD STOP S - BRIARCLIFF

Route ID: NE45  
FROM KELLY MS

3:20 PM ----- KELLY MIDDLE SCHOOL  
3:33 PM ----- ON HORN @ DALTON  
3:34 PM ----- ON HORN @ GOLDEN  
3:35 PM ----- ON HORN @ ANDERSEN  
3:36 PM ----- ON HORN @ HODSON LANE  
3:36 PM ----- ON HORN @ MELVINA  
3:38 PM ----- ON ELKAY @ 119 ELKAY  
3:41 PM ----- ON ELKAY @ HOOVER LANE  
3:42 PM ----- ON ELKAY @ FAIRWAY

[Type text]

Route ID: NE46

TO KELLY MS

8:17 AM ----- ON FIR @ RIVER RD  
8:18 AM ----- ON RIVER RD @ STULTS LTD  
8:19 AM ----- ON RIVER RD @ MCCLURE  
8:20 AM ----- ON RIVER ROAD @ E HILLCREST LTD  
8:21 AM ----- ON RIVER RD @ MERRY LTD  
8:22 AM ----- ON E HOWARD @ 43 E HOWARD  
8:23 AM ----- ON COPPING @ NORMAN  
8:24 AM ----- ON OWOSSO @ 375 OWOSSO  
8:25 AM ----- ON OWOSSO @ CAMELOT  
8:30 AM ----- ON RIVER AVE @ 130 RIVER AVE  
8:40 AM ----- KELLY MIDDLE SCHOOL

Route ID: NE46

FROM KELLY MS

3:20 PM ----- KELLY MIDDLE  
3:39 PM ----- ON FIR @ RIVER RD  
3:42 PM ----- ON RIVER RD @ STULTS LTD  
3:43 PM ----- ON RIVER RD @ MCCLURE  
3:44 PM ----- ON RIVER ROAD @ E HILLCREST LTD  
3:46 PM ----- ON RIVER RD @ MERRY LTD  
3:48 PM ----- ON E HOWARD @ 43 E HOWARD  
3:50 PM ----- ON COPPING @ NORMAN  
3:50 PM ----- ON OWOSSO @ 375 OWOSSO  
3:51 PM ----- ON OWOSSO @ CAMELOT  
3:54 PM ----- ON RIVER AVE @ 130 RIVER AVE

# Riding the Bus Safely

## Rules to follow when riding the bus

Every 4J School bus has a list of rules for all riders posted where they can be read.

Presented here is a simplified list of things that are important to remember when riding one of our 4J buses:

- 1** Stay seated on the bus at all times while the bus is in motion.
- 2** Keep the aisle clear of legs, feet and objects at all times.
- 3** The noise level is to be such that the driver can hear any noises or signals from outside the bus.
- 4** No offensive, obscene or abusive language.
- 5** No hands, arms, heads or objects are to be put out the windows. Also, no yelling out of the windows.
- 6** No eating or drinking is permitted on the buses. (Lengthy, out-of-town trips may cause exceptions to this rule.)



• Athletic Trips • Field Trips • Home to School

## The Oregon School Bus Stop Law

The law requires all traffic on an undivided roadway to stop when a school bus has its red lights flashing. Unfortunately, not all drivers obey the law.

## Crossing the road with the bus safety lights

For your safety, follow the directions shown here when crossing the road to go from bus to home.

- Exit the bus and walk to point X (10 feet in front of the bus)
- Look at the driver for the O.K.
- Walk to point Y and look both ways for traffic.
- Then, when it is safe, finish crossing.

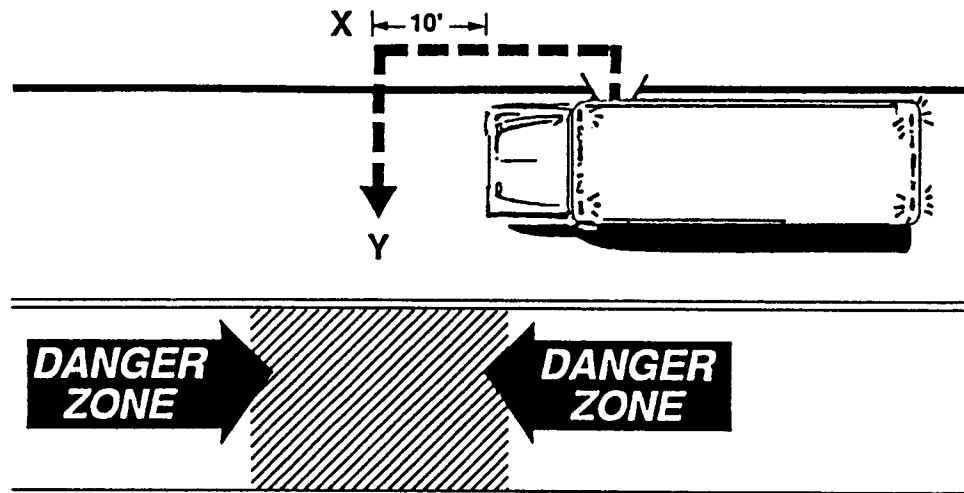

# Riding the Bus Safely

Continued from other side

## Emergency Equipment

All 4J School buses are supplied with a set of emergency equipment to be used in the event of a breakdown or an accident. Those items are:

- Three red triangle reflectors to warn traffic if the bus is stopped on the roadway;
- an ABC fire extinguisher;
- at least one first aid kit.

All buses are also equipped with a two-way radio that can be used to call any other bus or the transportation base. The key must be in the 'on' position with the mike button depressed when speaking and released to listen.

If the people on board the bus are in danger during an emergency because of the location or the condition of the bus, then the bus should be evacuated.



1. Student leaders take position to assist.
2. Evacuate one seat at a time.
3. Stay seated until your turn.
4. Rear door - jump with help of student leader.
5. Move at least 100 feet from bus.
6. Stay calm.

## EVACUATIONS

If an evacuation should be necessary, the driver will give that direction. All riders should remain calm. There is an emergency exit door at the rear of the bus in addition to the regular door at the front. To evacuate the bus as quickly as possible, both should be used with the first students out acting as leaders and assisting at both doors. Evacuation should be done one row at a time alternating left and right side, with row 1 being first out the front door and row 11 being first out the back.

After evacuating the bus, all riders should wait together at a location specified by the driver at least 100 feet from the bus.

Front and Rear Door Evacuation  
66 PASSENGER BUS  
(3 persons to a seat)

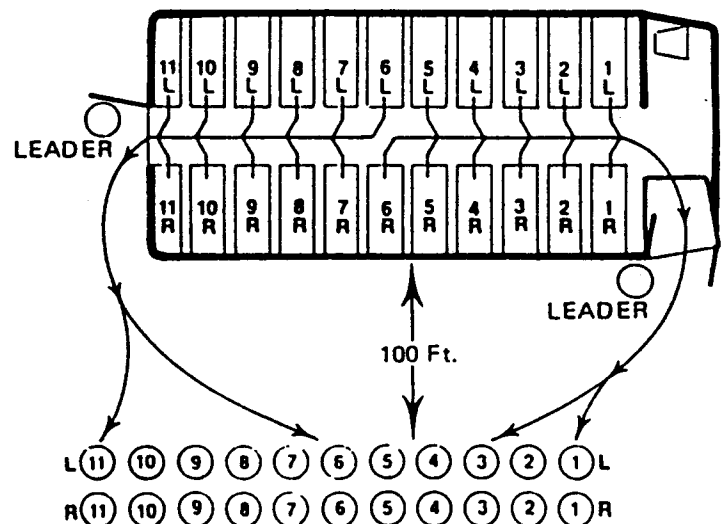



## Welcome Parents!

Greetings to all who have volunteered in the past and want to volunteer here in the future. We have a great tradition of welcoming parents and community volunteers to our programs. My name is Shelley Hoffman (Hoffman\_sh@4j.lane.edu) and this will be my 1st year as volunteer coordinator at Kelly Middle School.

Each year we strive to create more opportunities to involve parents. On the back of this page you will find the volunteer information sheet for 2009-2010 school years. All Kelly volunteers need to have a 4j background check to help at school. If you have not filled out and turned in a background check here at Kelly you can go to the Kelly website and print out a form. Please take a minute to fill out these forms and return them to school. I will be at the front of the building on the first day of school for the 6<sup>th</sup> graders and the first day for the entire student body if you'd like to meet me and personally give me your forms. As you can see on the form, we have many areas and times when parental help is really needed.

The hardest jobs for me to fill are the ones for Kelly Check-In day on Thursday, September 3. If you are a returning parent volunteer and would like to help the students get their schedules and / or collect their student fees, please e-mail me or call.

This school year is shaping up to be one of the best ever at Kelly. Please come and be a part of it!

Thank You,  
Shelley Hoffman  
541-914-8202

# Kelly Middle School Volunteer Interest Form 2009 - 2010

Name (First & Last):		
Address:		
City:	Zip:	
Home phone:	Work:	Cell:
Email:		
Student's Name:		Grade:
Student's Name:		Grade:
Relationship of student:		

**There are many ways that you can help our school. Please circle as many areas of interest where you would like to participate. The volunteer coordinator will contact you to set up a specific activity. Your time and support is greatly appreciated.**

<b>Choices for Volunteering (Please circle any areas of interest)</b>		
<b>Available Times:</b>	<b>Specific Needs:</b>	
Morning (8a-12p)	Library support	
Afternoon (12-5p)	Book Fair	
Evening (5p-8p)	Mentor at lunch	
Mon Tue Wed Thu Fri	Health checks	
<b>Event Assistance:</b>	<b>Event Accounting:</b>	<b>Language/s:</b>
River Walk - serving food	River Walk	English
Fall Fest - sign-ups	Book Fair	Spanish
Winter Fest - sign-ups	Magazine Sale	Japanese
Friendship Fest - sign-ups		Other:
8th Grade Graduation		

<b>Emergency Contact Information (please list two people)</b>		
Name:	Relationship:	Phone:
Name:	Relationship:	Phone:
Primary Dr:		Preferred hospital:
Do you have a medical condition, or are taking medication/s in case of emergency? Yes No		
If yes, please explain:		

For Office Use Only:  
 Background Check Processed:  
 Status: Approved Disapproved  
 Follow Up Completed Date:

Date:

**MON**

**TUE**

**WED**

**THU**

**FRI**

Kelly Middle School  
September & October 2009

September				
	1	2	3 3-6p Check In Day	4
7 <b>NO SCHOOL</b> Labor Day	8 <b>NO SCHOOL</b> Staff Planning Day	9 9:00a-2:30p Classes Begin 6th Graders Only! 2-3p New Student Orientation	10 9:00a <b>All Students Report!!</b>	11
14	15	16	17	18
21 School Pictures	22 10-10:45a 6th Grade Parents Coffee w/José Last Name; A-M	23 3:40p Site Council Meeting	24 6:30p Open House	25
28	29 10-10:45a 6th Grade Parents Coffee w/José Last Name; N-Z	30	October	
5 7p Kelly Co-Pilots	6 10-10:45a 6th Grade Parents Coffee w/José Spanish Speakers	7	8	9 <b>NO SCHOOL</b> State Wide Inservice
12	13	14 3:30p Site Council Meeting	15 6:30-8:30p RiverWalk Party	16 <b>NO SCHOOL</b> Progress Reports/ Staff Development
19	20	21	22	23
26	27	28	29	30 Fall Fest

Kelly Middle School  
850 Howard Avenue  
Eugene, OR 97404

NONPROFIT ORG  
US POSTAGE  
**PAID**  
EUGENE OR  
PERMIT NO 201



Inside is your Back to School  
calendar & newsletter.